



PLASTGrommet



23/24

CATALOG

Finishing solutions for banners & fabrics

COMPANY PRESENTATION

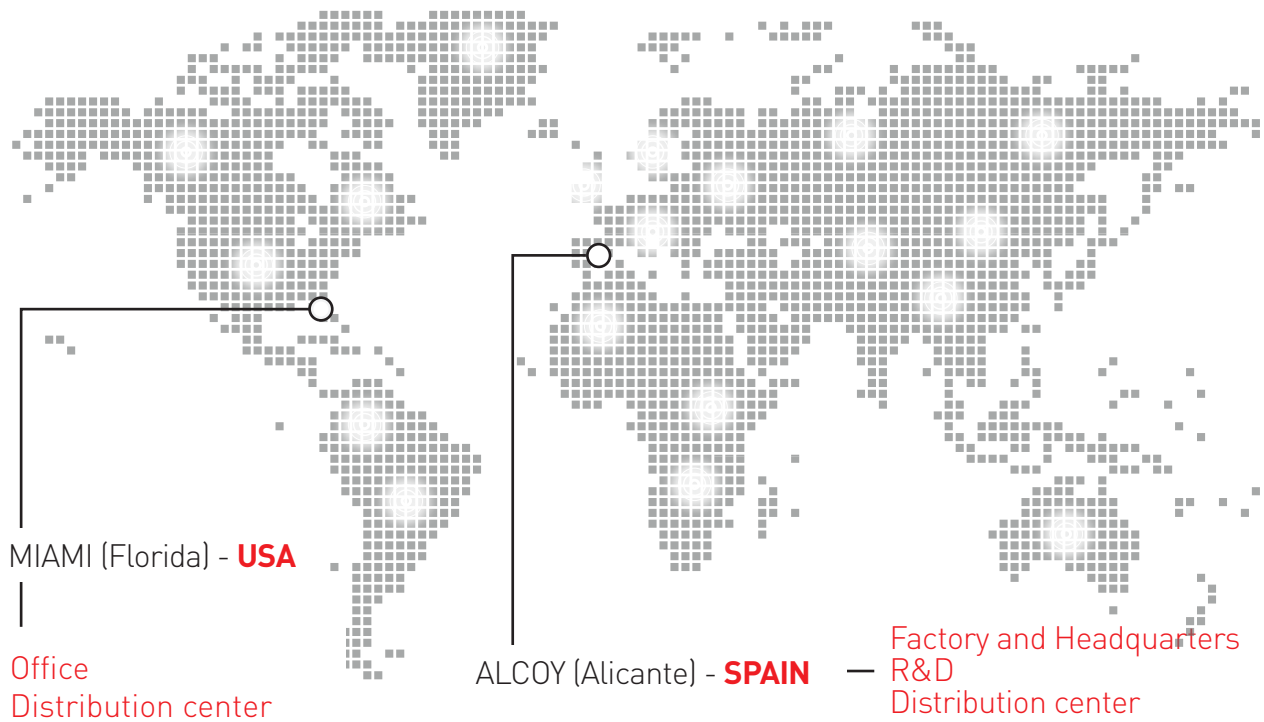

1990

Plásticos Alco was founded to manufacture industrial parts using injection moulding machines for several sectors such as agricultural equipment, food packaging...

2004

Our brand **PLASTGrommet** was created to supply clear recyclable grommets for digital printing market, later on grommet machines and storage racks were added to our offer.

2017

Opening of a **US subsidiary (Miami)** to serve the North American market.

2023

We are now **present in more than 30 countries** helping customers to improve their banner finishing operations.

We are **exporting 80%** of our turnover.



European manufacturing



R+D Department



Distribution centers in Europe and USA



Technical & Aftersales Service



Guarantee



CE Marking on equipment



Environmentally Responsible



Sales in more than 30 countries

01

BANNER FINISHING SYSTEMS

AUTOMATE YOUR BANNER FINISHING PROCESS

OPTIMIZE LABOR

IMPROVE FINISHING WORKFLOW



02

GROMMET MACHINES

HAND PRESSES

SEMI-AUTOMATIC

FULLY AUTOMATIC



03

GROMMETS

CLEAR GROMMETS

METAL GROMMETS



04

MEDIA STORAGE RACKS & MEDIA ROLL LIFTERS

ORGANIZE YOUR MEDIA ROLLS

EASILY LOAD PRINTERS WITH ONE OPERATOR



05

CAR WRAPPING SQUEEGEES

WET & DRY USE MICROFIBER SQUEEGEES



EQUIPMENT TO BOOST YOUR FINISHING PRODUCTIVITY. HIGHER QUALITY BANNERS WITH FASTER FINISHING TIMES!

NEW



RollRewinder

The easy way to **roll banners** for shipping.

Banner to Roll



NEW

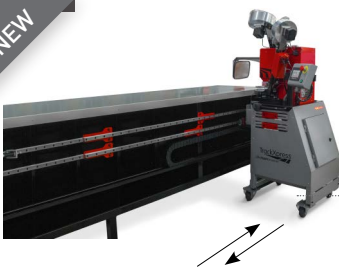

TrackXpress

Automatic **grommet press** for finishing tables.

Grommeting



NEW



Roll2Roll Range

Three options to speed up your finishing process.

Grommeting



Welding



Roll to Banner



Roll to Roll



The Finishing Station

Finishing station with **welding + grommeting** in ONE step.

Grommeting



Welding



All In One

Automated in-line solution that integrates welding, grommeting and slitting or rewinding.

Grommeting



Welding



Roll to Banner



Roll to Roll





RollRewinders



Roll Rewinder is a standalone roll rewinding station to prepare banners for shipping.

RollRewinder XXL



RollRewinder



FEATURES

- Adjustable rotation speed.
- Turns in two directions. Winding and unwinding.
- Expansible shaft.
- Works with or without cardboard core.
- **RollRewinder:** 1500 mm shaft. (59")
- **RollRewinder XXL:** 2700 mm shaft.(106")



TrackXpress



Automatic grommet press Multipress (page 11) that adapts to almost any finishing table.

FEATURES

Easy to move. Unidirectional wheels and linear roller guides.

Schock absorber system for uneven ground.

Adjustments for height and depth.

Track is supplied in sections to match your table with:

- Linear guides.
- Pneumatic & electric wiring.
- Drag chain.



(Finishing table is not supplied.)

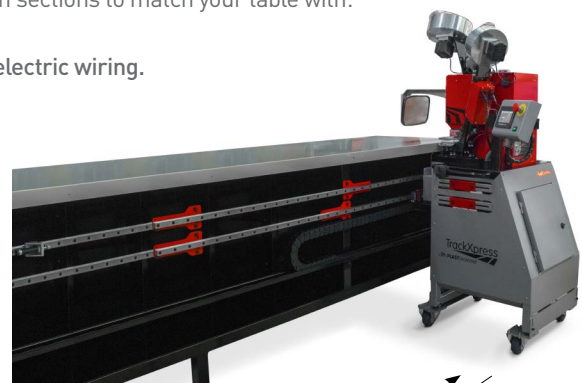

The Finishing Station



Finishing station to weld and grommet banners. Two processes in **ONE** step.



FEATURES

- Unique built-in station with a hot air blower and an automatic **grommet machine**.
- Reduce banner handling and **save time** as you only need to prepare banners once for finishing.
- **Conveyor belt** synchronized with driven rollers for constant tension.
- **Finishing assistant** to calculate automatically grommet position. Operator inputs banner size and number of grommets/distance and PLC will evenly split them along the edge.



Welding options: hem, keder, webbing tape or pocket

Part#: TFS

WELDING OPTIONS

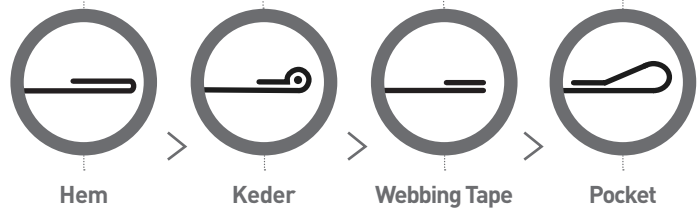

OPTIONAL EQUIPMENT

Banner handling is always an issue. The conveyor belt and the extension tables with rollers will help operator to feed the banner effortlessly. We recommend having on each side of the station enough tables to match your banner length.

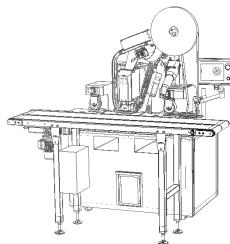

TFS + Conveyor belt



Part#: TFS-CT

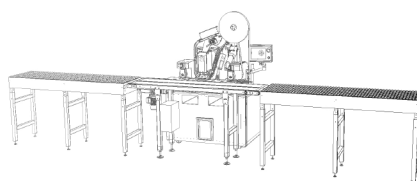
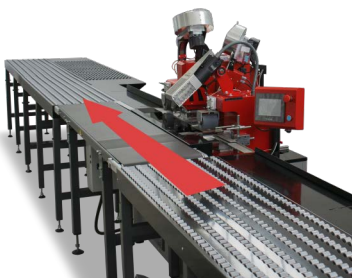

TFS + Conveyor belt+ Roller tables



Part#: TFS-MR



Roll2Roll Range



R2R Welding

If you produce **fence-mesh** or banners on a roll, to weld 50 m or 100 m rolls is a difficult task for any print shop as rolls are heavy and difficult to handle.

Roll2Roll Welding **automates the process of welding** both sides of the roll simultaneously using **hot air technology** with low noise level compare with other systems.

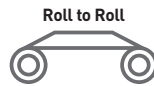
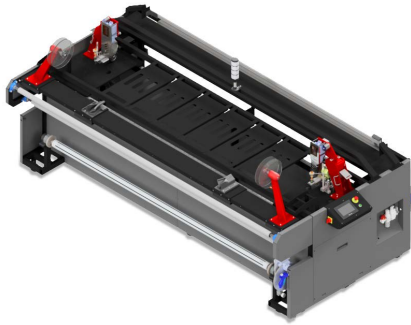

Three different welding options:

1. Hem.
2. Webbing tape.
3. Single flap keder.

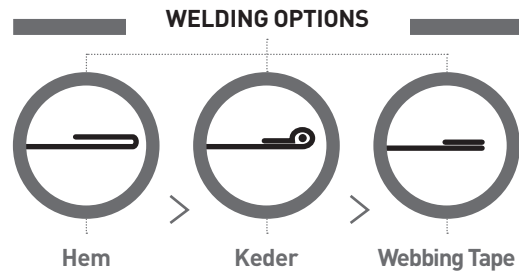

R2R Eyeleting

Grommeting both sides of a roll is a **time-consuming task** if you do not have the correct equipment at your shop.

If you need to grommet both sides because you have welded the roll with Roll2Roll Welding, you are using **pre-hemmed** media or you need to finish single layer banners, Roll2Roll Eyeleting is the machine you have been looking for.

Automatic grommet setting selecting **distance between grommets** (this figure will be constant for the entire roll).

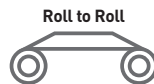
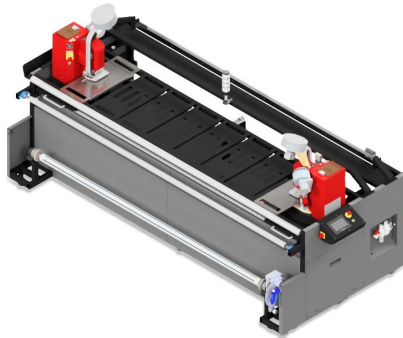

Unique 2 in 1 feature. One of the machines turns 180° and can be used as a standard grommet press to finish the short sides of the banners.

R2R Eyeleting PRO

This machine has same features as Roll2Roll Eyeleting, incorporating a **motorized traction gantry** and an **automatic slitting** device. Roll2Roll Eyeleting Pro offers great **flexibility** in terms of finishing as you can grommet full rolls or **grommet banners cut to a certain length**. **Precise control** of the grommet and cutting **position** with the use of a **servo motor**.

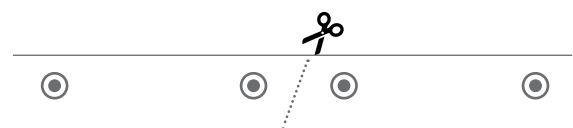
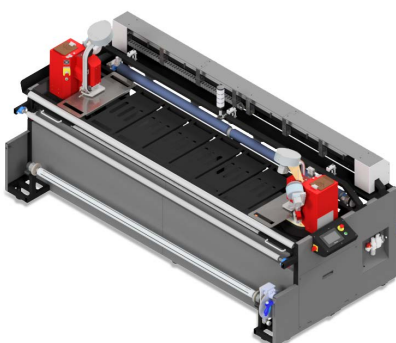

When producing banners, it is possible to set two grommets together to slit between them (last grommet of one banner/first grommet of the other).

Automated in-line solution to finish banners

All In One

All In One integrates in a single process **welding, grommeting and slitting** to finish large banner jobs. As it eliminates the time needed to weld hems on another finishing station you are not only reducing time but also space while you are boosting your productivity.

All in One is the 360° solution for banner finishing as you **will reduce lead times and labor costs**.

Hem welding

Grommeting

Slitting or Rewinding



Vision system to recognize grommet and cutting marks.
 Optional **webbing tape & keder guides**.
 Optional **width adjustment** system.

WELDING OPTIONS

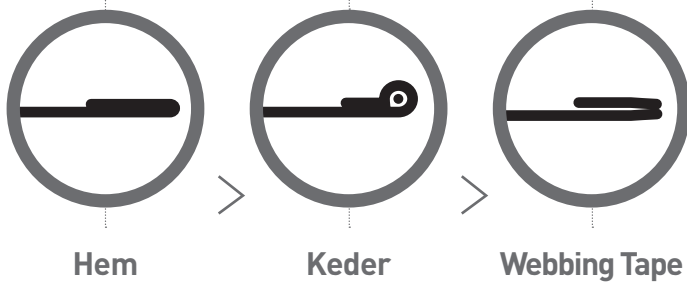

CUTTING OPTIONS

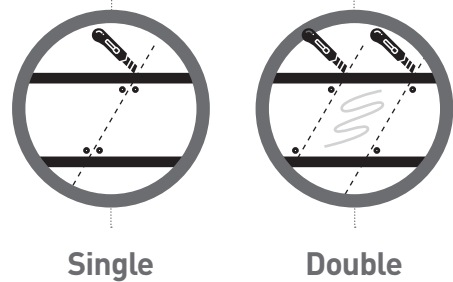

FEATURES

- 1 Automated in-line solution.**
The processes of welding, grommeting and slitting are labour intense and slow, the bottleneck of the print workflow. Integrating all of them in a single machine will improve productivity and reduce lead times.
- 2 Vision system.**
Camera will detect grommet and cutting marks to perform these operations automatically.
- 3 Automatic roll edge alignment.**
- 4 Rewinding or slitting.**
All In One can finish full rolls with the rewinding module (fence mesh) or to finish individual banners cut to the desired length.
- 5 Media.**
It is possible to finish mesh, PVC banners or PE.
- 6 Speed and productivity.**
Speed may vary depending on the type of media used but as average, a **50-meter banner roll** will take about **7 minutes** to be finished, including hemming, grommeting and slitting.
- 7 Remote support.**
Wi-Fi connection for technical support.
- 8 Production data monitoring.**
Via CSV file with material description, number of banners, operating time...
- 9 Available sizes.**
All In One is manufactured in: 160 cm (63") - 240 cm (94 ½ ") - 320 cm (126")

MODULAR SYSTEM



In-line Rewinder

To finish full rolls (fence banners for example).



Off-line Rewinder



Grommeting & slitting station

Adjustable distance between grommet machines.

Vision system to read grommet and cutting marks.

Precise slitting unit with rotary cutter built-in.



Welding station

Hot air welders with setting adjustments through touch screen.

Accumulating system (dancer) for continuous welding.

Different welding options: hem, webbing tape and keder.



Loading station

Easy loading system with pneumatic shaft.

Edge alignment mechanism with photosensor and pneumatic adjustment.

Scan me!



Evolution

BASIC LINE (BANNERS)

Pneumatic **automatic** machine for: **PVC banners, mesh, Coroplast and gym mats.**





Evolution has been **designed for mid-volume** users who do not require as many features as Multipress or AutoCross can offer but still need to work with an automatic machine.



Available for:

- PLASTGrommet #3 **clear** plastic grommet

FEATURES

-  **Laser pointer** for accurate setting.
-  **Operator safety first:** If any of the security devices is removed, machine will not work.
-  Sets **2000 grommets/hour.**
-  **Grommet spacer** to set all of them to the same distance.



AutoCross

PRO LINE (FABRICS & BANNERS)







Electric automatic machine for banners and fabrics. Autocross has been designed for volume users who do not require as many features as Multipress can offer but still need to work on a wide range of materials.



Available for:

- PLASTGrommet #2 **clear** plastic grommet
- PLASTGrommet #3 **clear** plastic grommet
- PLASTGrommet #2 **metal** grommet (brass)
- PLASTGrommet #3 **metal** grommet (brass)

FEATURES

-  **Materials:** fabrics, corrugated plastics, clear foil, PVC banners ...
-  **Adjustable cutting pressure and grommet closing pressure,** even on thin fabrics material will not roll.
-  **Laser pointer** for accurate setting.
-  **Safety first:** If any of the security devices is removed, machine will not work showing a warning light.
-  **Powerful engine. 3000 grommets/hour.** Works with an 1 HP engine with transmission belt.
-  **Grommet spacer** to set all of them to the same distance.



MultiPress

PRO LINE (FABRICS & BANNERS)











MultiPress has been designed with industrial users in mind, it is fast (**electric**), reliable (washer detector), features a double washer raceway, it can work with fabrics as well as PVC banners and it will inform you when maintenance is due, a must have for companies finishing large number of banners.



Available for:

- PLASTGrommet #2 clear plastic grommet
- PLASTGrommet #3 clear plastic grommet
- PLASTGrommet #2 metal grommet (brass)
- PLASTGrommet #3 metal grommet (brass)

FEATURES

-  **Types of materials:** fabrics, corrugated plastics, clear foil, PVC banners...
-  **Adjustable cutting and grommet closing pressure,** even on thin fabrics material will not roll.
-  **Laser pointer** for accurate setting.
-  **Operator safety first:** If any of the security devices is removed, machine will not work showing a warning message on the screen.
-  **Powerful engine. 3000 grommets/hour.** Works with an 1 HP engine with transmission belt.
-  **Grommet spacer** to set all of them to the same distance.
-  **Pre-cutting mode** for fabrics. Pressing the pedal, machine will first cut the hole and then set the grommet (no need to press the pedal again) controlled by the PLC.
-  **Quality work sensors.** During the setting, if washers are not in the correct position, machine will inform you. An automatic blower will push the washer in to the setting area.
-  **Double washer supply on raceway.** Double rail system to feed washers. If one channel is empty, the other supplies.
-  **Touchscreen.** Full color touch screen to interact with the machine. Working modes, language, number of grommets.
-  **Information and counters.** Preventive maintenance warnings and grommet counters (total and per shift).

Part#: MULTI



PRO LINE



Touchscreen

Double washer supply raceway



HPS025

BASIC LINE (BANNERS)

Portable self piercing grommet press for **#3 clear plastic grommets**.

Our entry level hand press is the perfect tool for small sign shops. There is no need to work on a fixed position and you can easily set grommets on your bench or ground.

This grommet press has been designed to set clear grommets on different materials as PVC banners, Coroplast... but not on fabrics where it can create wrinkles around the grommet.



Reasons why you shouldn't miss this hand press:

- No need to precut the material, machine does cutting and setting in a single operation.
- **Portable**, move the press and not the banner.
- European manufacturing.



Part#: HPS025

Available for:
- PLASTGrommet **#3 clear** plastic grommet

#3 (12MM) DIE: PART# 2002012AUTO

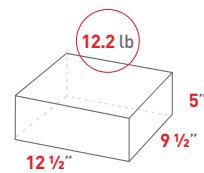

CornerRounder

Perfect tool to round edges! The Corner Rounder will round off corners of different materials such as aluminum composite (Dibond®), PVC, cardboard, paper and many other materials in a quick and precise way.



- **Radius** 6, 10 y 14 mm.
- Cut materials **up to a maximum of 15 mm thickness**.

Available sizes:



Part#: PHTICR



OPTIONAL

It is possible to **transform** an existing hand press **HPS025** into a **Corner Rounder** using kit code PHTIKCR.

Includes: 1. Blade. 2. Cutting platform. 3. Cutting adjustment tool.

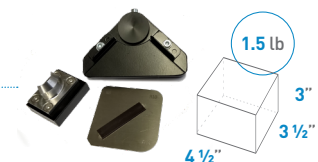

Part#: PHTIKCR

Queen & SpeedQueen

BASIC LINE (BANNERS)

Our range of lightweight pneumatic grommet machines offers shop owners an affordable way to finish their banners and print jobs effortlessly, reducing their production times and ensuring a constant quality setting during the finishing process.

These grommet presses have been designed to set **PLASTGrommet #3 clear grommets** on different type of materials: PVC banners, Coroplast... but not on fabrics where they can create wrinkles around the grommet.

Two models to choose from

QUEEN
with Thumb Button

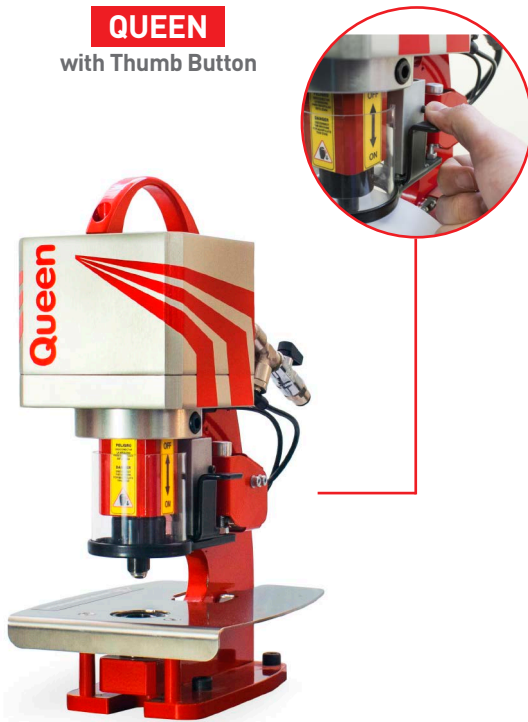

SPEED QUEEN
with Foot Pedal



Part#: QUEEN_12_U

Available for:

- PLASTGrommet #3 clear plastic grommet

Reasons to upgrade to a pneumatic press:

- **No effort required** to grommet banners.
- Safety guard that covers setting area.
- No assembly needed, just plug the air hose.
- #3 die for clear plastic grommets **included**.
- Heavy duty machine for large volume shops.
- Lightweight, easy to move (24 lb).

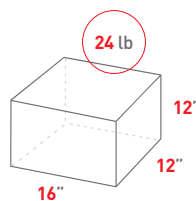

Part#: SQUEEN_12_U

Available for:

- PLASTGrommet #3 clear plastic grommet

BASIC LINE



Clear grommets

Using clear grommets, you can **RECYCLE** your polyester fabric banners with the grommets still intact!. The **ULTIMATE GROMMET SOLUTION** for banners.



#2 Grommet (Ø9.5 mm)

500 pcs per pack

- Part#: OA95TQ Standard
- Part#: OA95TLQ Long neck

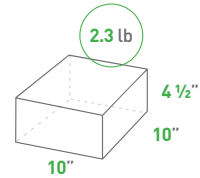

#3 Grommet (Ø12 mm)

500 pcs per pack

- Part#: OA12TQ Standard
- Part#: OA12TLQ Long neck

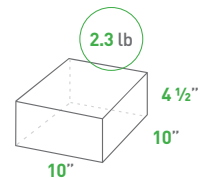

Grommets for any kind of applications. Invisible, strong and recyclable.

<p>INVISIBLE</p> <p>Enhance overall appearance of finished prints</p>	<p>100% POLYESTER WASTE PRODUCT</p> <p>When combined with a polyester fabric Free of PVC, heavy metals and phthalates</p>	<p>RESISTANT</p> <p>Do not rust Strong and durable UV protected</p>	<p>COST-EFFECTIVE</p> <p>More cost-effective solution than brass Stable prices</p>	<p>CAL PROP 65 COMPLIANT</p> <p>Our clear grommets have been tested under Cal Prop 65</p>
--	--	--	---	--

Remember, not all plastic grommets are made the same. Use PLASTGrommet clear plastic grommets to take advantage of all of the features above.

100% Recyclable grommets



Recyclable with PP and PE banners

No more rust



UV protection suitable for outdoor.

Invisible



Improve your banners with clear grommets

Environmentally friendly



Free of heavy metals and anti-corrosives PVC free

Metal grommets for automatic machines

We have a complete range of **metal grommets** for different applications. Order the specific dies to use them on PLASTGrommet equipment.

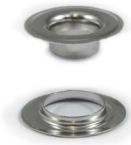

#2 Grommet (Ø9.5 mm)

FINISHING



NICKEL-PLATED

Part#: PCBR95634A-B

BRASS



#3 Grommet (Ø12 mm)

FINISHING



NICKEL-PLATED

Part#: PCBR12634A-B

BRASS

1 Box contains
16 packs

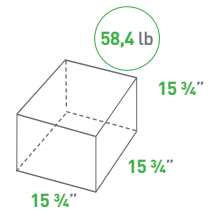

(500 pcs per pack)

Grommets with neck washer to be used on **automatic machines**
Machines: **Autocross** or **Multipress**.

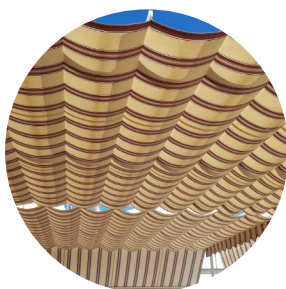

INNOVATIVE SOLUTIONS FOR ROLL STORAGE AND ROLL HANDLING

Choose the correct model according to your needs



BullRack

Store more rolls in less space!



Media Poles & rubber tips included

Our heavy steel construction Bull Rack has been designed with sign makers in mind as you can easily access any of the 15 rolls (up to 64" wide).

It is mounted on heavy duty locking wheels for easy maneuver around your print shop and there is an optional vinyl cutter available.

Product dimensions: 73" x 17" x 58" (L x W x H).

Part#: PHTIBR+

Flat Packaging Shipped disassembled.

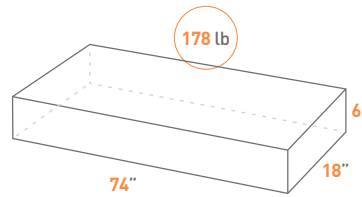

Cutter (optional)

Ref. Cutter: PHTIBRC

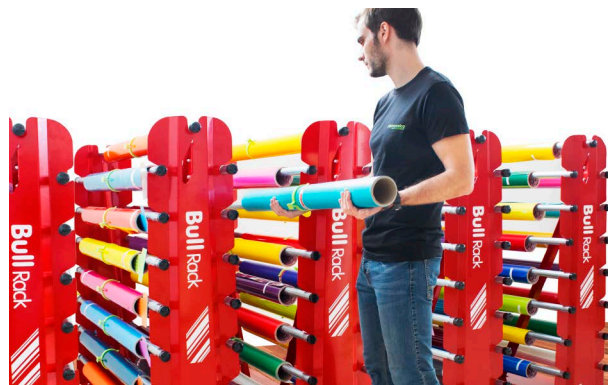
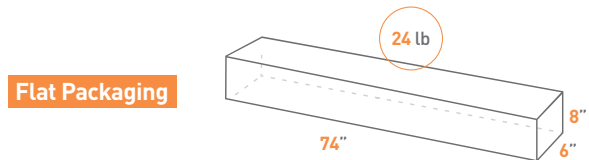
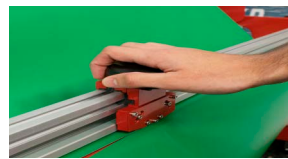

1.015 lb	15	64"	6 1/2"	2"/3"
LOADING CAPACITY	ROLLS	ROLL SIZE	Ø ROLL	CORE

RollClips

Take care of your vinyl rolls and printing materials

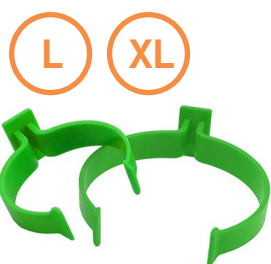

- Faster and easier than tape, rubber bands or paperclips.
- Designed with a finger pull for **easy handling**.
- Two sizes per bag (L + XL).
- Packs of 12 or 50 pcs.

Part#: PHTIASR12 Part#: PHTIASR50

EasyRack

The ergonomic solutions for roll storage!

Avoid back pain when loading and unloading rolls due to its ergonomic design. **Transport and unload rolls effortless.**



Part#: PHTIBMA



Flat Packaging
Shipped disassembled.

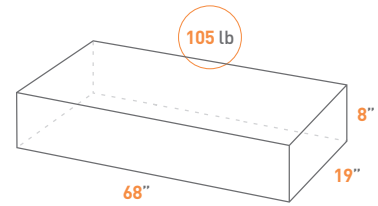

1.015 lb	16	64"	7 1/2"	3"
LOADING CAPACITY	ROLLS	ROLL SIZE	Ø ROLL	CORE

WallRack

Save space using walls

Use your empty walls to store your vinyl. Can be fixed to the wall and also on the ground for better stability.

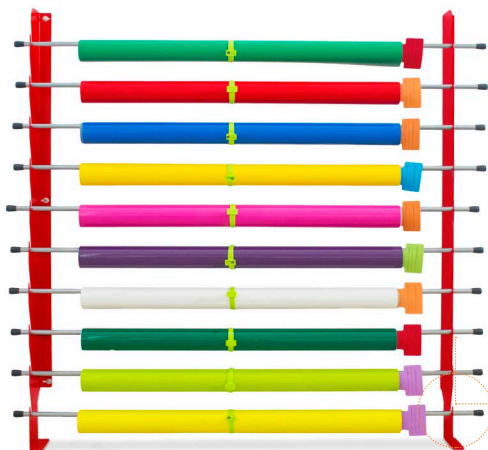

Media Poles & rubber tips included



Baseboards or wiring ducts are not a problem

Flat Packaging Shipped disassembled.



660 lb	10	64"	7 1/2"	2"/3"
LOADING CAPACITY	ROLLS	ROLL SIZE	Ø ROLL	CORE

Part#: PHTIWR

BullRackXXL

126" rolls won't be a problem anymore!



Media Poles & rubber tips included

Perfect for storing and transporting large rolls. Compatible with our range of media lifters.

Part#: PHTIBRXXL



Flat Packaging

Shipped disassembled.

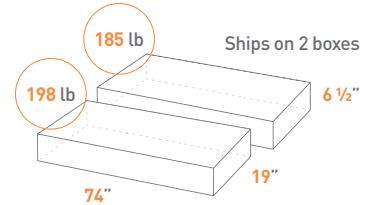

1,750 lb

LOADING CAPACITY

8

ROLLS

126"

ROLL SIZE

6 1/2"

Ø ROLL

Jumbo Rolls Transporter

Adjustable width

For super-wide format rolls. Compatible with our range of media lifters. (M.O.Q: 2 units)

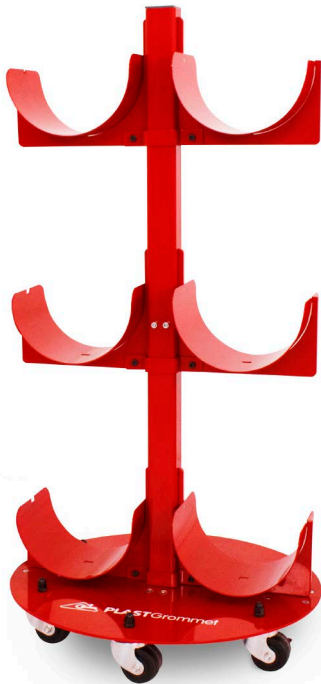

Part#: PHTIJB6



Flat Packaging

Shipped disassembled.

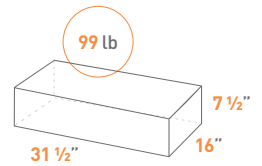

2,650 lb (with 2 Jumbo)
4,000 lb (with 3 Jumbo)

LOADING CAPACITY

6

ROLLS

198"

ROLL SIZE

10"

Ø ROLL

Scan me!



Demo work

YouTube



MultiRack

Easy access to 36 rolls!



Small footprint with great storage capacity.

Part#: PHTIMR

Flat Packaging Shipped disassembled.

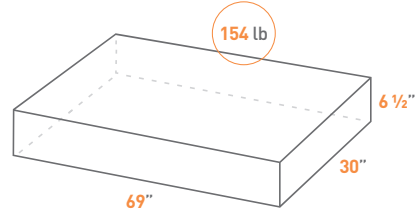

1.015 lb

36

48"

6 1/2"

2"/3"

LOADING CAPACITY

ROLLS

ROLL SIZE

Ø ROLL

CORE

Mobile12

Basic storage for 2" core!



Designed so that your 2" core rolls are within your reach at any time.

Part#: PHTIBM12R

Flat Packaging Shipped disassembled.

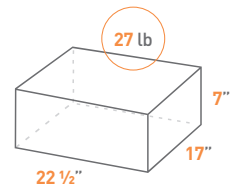

1.015 lb

12

64"

7"

2"

LOADING CAPACITY

ROLLS

ROLL SIZE

Ø ROLL

CORE

Mobile16

A must have in every print shop!

One of our best sellers. Keep up to 16 rolls on hand so you don't slow down your work.



Part#: PHTIBM16R

Flat Packaging Shipped disassembled.

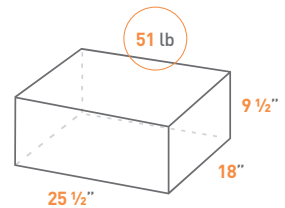

1.015 lb

16

64"

7"

3"

LOADING CAPACITY

ROLLS

ROLL SIZE

Ø ROLL

CORE

Compact Lifter

Hydraulic Foot Pump



An essential piece of equipment for every **wide format printer!**

FEATURES

Part#: PHTICL

- Hydraulic. Works by **pressing the footpedal.**
- Lock ramps up to prevent roll from falling.
- Lifts up to **4'.**

lb
440 lb
LOADING CAPACITY

196"
FOR ROLLS UP TO

10 1/4"
MAX. ROLL Ø

3 1/8"
WHEELS HEIGHT

Compact e-Lifter PRO

Battery operated



The media lifter with **the biggest loading capacity.**

FEATURES

Part#: PHTICL-PRO

- **Battery-powered (roll) lifter.**
- Lock ramps up to prevent roll from falling.
- Built-in charger.
- Lifts up to **4'.**
- Battery indicator.
- Built-in charger.

lb
660 lb
LOADING CAPACITY

196"
FOR ROLLS UP TO

11 3/4"
MAX. ROLL Ø

3 1/8"
WHEELS HEIGHT



As simple as **pressing a button.**
Effortlessly lift rolls pushing a button

Scan me!



Demo work

YouTube



WORKING MODES (both models)



Transport:
The ramps are raised and act as a stop to prevent material from falling during transport.



Work:
Horizontal position to effortlessly load and unload the roll onto your printer at the desired height.



Floor loading and unloading:
Ramps down to load or unload of the roll to/from the ground.

PRO LINE

★ ★ ★ ★ ★ ★ ★ ★ MANUFACTURED IN EUROPE

Car wrapping squeegees with unique characteristics in terms of durability and resistance.

Wet & Dry use Marathon Range

Microfiber Marathon Squeegee

- Two layers of ultra-soft **Microfiber edge** to avoid scratching the graphics.
- Microfiber **lasts longer** than any other material.
- It can be used either **wet** or **dry**.
- The unique microfiber edge makes this squeegee perfect for **Chrome films**.



Ref (10cm - 4"): PHTIEHAV

Ref (15cm - 6"): PHTIEHAV15

Microfiber Marathon FLEX Squeegee

- Same properties as Marathon but with a higher degree of **flexibility**.
- Choose for your car wrapping jobs the Marathon model that better suits your needs!.



Ref (10cm - 4"): PHTIEHAVFX

Ref (15cm - 6"): PHTIEHAVFX15

GOLD SUPER-Flex Squeegee

- The **perfect combination**: Soft enough to have flexibility but hard enough to keep the shape for a long time.
- It has been designed to last longer than the everyday-use models, an "all performance squeegee".



Ref (10cm - 4"): PHREP10G

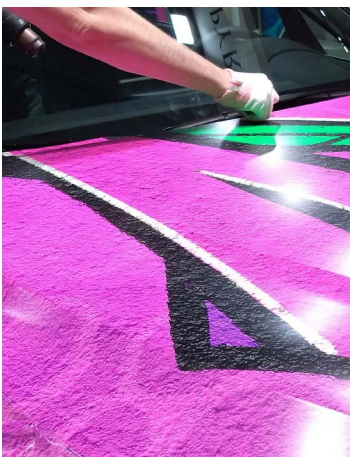

BASIC LINE

★ ★ ★ ★ ★ ★ ★ ★ MANUFACTURED IN EUROPE

Daily Use Squeegee - Green

This squeegee model can be used for light applications on solid flat substrates.

Ref (10cm - 4"): PHREP10V

Ref (15cm - 6"): PHREP15V



FLEX Squeegee - Blue

This model has a higher flexibility rate and a medium memory.

Ref (10cm - 4"): PHREP10A

Ref (15cm - 6"): PHREP15A



Felt Edge Squeegee - Red

Our red felt edge squeegee is a unique combination of our everyday-use squeegee with a soft, smooth felt edge to protect the surface of digital prints.

Ref (10cm - 4"): PHREP10RF

Ref (15cm - 6"): PHREP15RF



PLASTGrommet **manufactures** a complete range of squeegees for different applications, from windows graphics up to Chrome films.

All of them feature two raised areas in the middle to offer a nice and good grip, four rounded corners and they are available in two sizes, 4" and 6".





PLASTGrommet



www.plastgrommet.com



Download on
pdf format



Factory and Headquarters | PLASTGROMMET S.L.U.
Carretera Font Roja, 23 | 03801, ALCOY (Alicante) | SPAIN
Tel: +34 965 339 969 | info@plastgrommet.com

US Office | PLASTGROMMET, INC.
8950 SW 74th Ct., Suite 1406 | Miami, FL 33156 | USA
Tel: +1 305 447 7040 | usa@plastgrommet.com

